



OIL SEALS & BEARINGS CENTRE LTD.



**BEARINGS | SEALS | MAINTENANCE PRODUCTS | LUBRICANTS
HYDRAULICS | CHAINS | SPROCKETS | COUPLINGS
TAPER BUSHES | VEE BELTS | VEE PULLEYS**

ABOUT US

Since 1977, with the establishment of a small bearing shop in Nairobi, our company has consistently extended its products and service offerings and enjoyed a proud history of opportunity-driven expansion. This expansion has spearheaded the continuous evolution into the consolidated power house that is OIL SEALS & BEARINGS CENTRE LTD.

- ISO 9001:2008 certified company
- Top 100 mid-sized company in Kenya
- A major company known in East Africa
- More than 50 employees – experts in every field of OIL SEALS & BEARINGS CENTRE LTD. endeavours.
- Unrivalled product availability from more than 25 locations.
- Total customer support from spare part supply to engineered solutions and site work.

Our continually expanding product and service ranges now cover 11 defined disciplines and comprehensively cater for all industrial sectors.

This breadth and scope uniquely positions OIL SEALS & BEARINGS CENTRE LTD. as an all-encompassing solutions provider with the ability to combine products and services to solve productivity issues on entire production processes.

- BEARINGS
- SEALS
- MAINTENANCE PRODUCTS
- LUBRICANTS
- HYDRAULICS
- CHAINS
- SPROCKETS
- COUPLINGS
- TAPER BUSHES
- VEE BELTS
- VEE PULLEYS

ROLLING THE INDUSTRIES

Every day, machines are put to work, powering mass production and driving modern industries forward. Inside every machine, a multitude of parts are hard at work, the role of each and every component is essential to the machines operation and has a vital part to play in the ongoing pursuit of maximized productivity. From the smallest bearing to the gigantic drive systems. All engineering components of OIL SEALS & BEARINGS CENTRE LTD. contribute to the full spectrum of production operations.

AGENTS AND DISTRIBUTORSHIP

In the bid to procure cutting-edge components at competitive prices, OIL SEALS & BEARINGS CENTRE LTD. is able to capitalize on long-standing relationship with leading manufacturers dedicated to excellence in design and production.

TIMKEN - USA



NTN-SNR - FRANCE



INA -GERMANY



FAG -GERMANY



STOCKIST OF SEALS

- NOK
- TTO
- FPE

GETTING THEM OUT TO YOU

Consignments are couriered via reputed logistics partners. With a contracted rate, goods are collected from our premises and delivered to the customers door step promptly & without hustle. It is through the sheer size and reach with our logistics partners that OIL SEALS & BEARINGS CENTRE LTD. can be found wherever industry has established itself.



STOCK HOLDING CAPABILITY

- 10,000 sqm of stock holding
- Over 150,000 product line item
- Daily courier transportation to upcountry
- Over 10 tons of imported stock landing per month
- Procurement of non-stock items in shortest possible time

TRAINING

To foster this technical expertise, we cultivate a mindset of continued learning and personal development in our people. We train our people and ensure a continual supply of talent into OIL SEALS & BEARINGS CENTRE LTD. organization.

- The expertise to properly evaluate each client's production operations with a specialist authority.
- The competence required to ensure the best possible selection, application and operation of our products.

SPECIALIST SERVICES ON SITE

Our technical team delivers a variety of specialist services on-site, in sync with customer needs for enhanced operational efficiency and maximized productivity. From custom design capabilities, to on-site maintenance and support, plus hands on training to enhance customer knowledge.

SERVICES

- On-site breakdown maintenance, repair and refurbishment.
- Product installation, commissioning and trouble shooting.
- Planned maintenance.



Training

Knowledge

useful ability

backbone of

quired for

SPECIALIST OFFERINGS

- Customized product design
- System design and evaluation
- Reliability investigations and recommendations
- Design and installation of unitary and bulk materials handling

SUPERIOR SERVICE

OIL SEALS & BEARINGS CENTRE LTD. offers a service that satisfies the requirements of continuous process and multi shift operations. It is an integral part of our mission to offer one source of supply to the replacement, resale and OEM markets.

It's a trusted offering that sets OIL SEALS & BEARINGS CENTRE LTD. apart in a competitive market place backed up by ISO 9001:2008 quality certification.

This guarantees our activities conform to the highest quality assurance standards and has already established OIL SEALS & BEARINGS CENTRE LTD. as the preferred engineering partner to many prestigious companies and organisations.

The company is embodied by a unified team of skilled, experienced and motivated people who get involved in meaningful client consultation, offering expert advice with added insight and foresight in relation to our products. We strive to be an integral part of our client's business, their productivity and their operations.

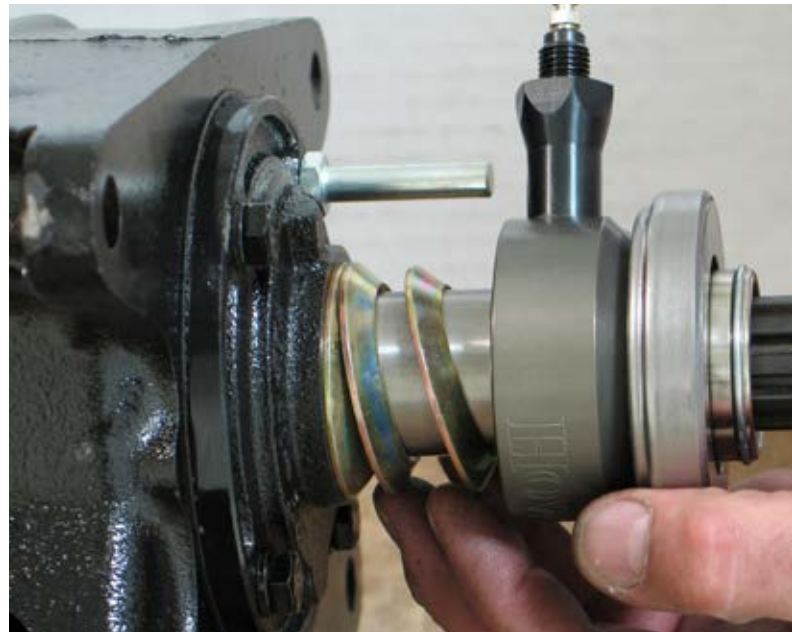

BEARINGS

OIL SEALS & BEARINGS CENTRE LTD. proudly supplies the full range of bearing products and associated mechanical components to industry, helping to maximize operational up-time at steel mills, mines, plastic industries and major agro-industrial producers.

Our extensive and unbeaten product range includes bearings in all sizes from giant mill bearings to miniature bearings as well as all related systems and products.

- **BALL BEARINGS**
- **ROLLER BEARINGS**
- **CAM FOLLOWER BEARINGS**
- **CYLINDRICAL ROLLER BEARINGS**
- **TAPER ROLLER BEARINGS**
- **DOUBLE TAPER ROLLER BEARINGS**
- **LINEAR BEARINGS**
- **MINIATURE BEARINGS**
- **NEEDLE ROLLER BEARINGS**
- **ROD END BEARINGS**
- **SPHERICAL ROLLER BEARINGS**
- **SPLIT BEARINGS**
- **THRUST BEARINGS**
- **PILLOW BLOCK UNIT**
- **TAKE UP UNIT**
- **PLUMMER BLOCK UNIT**
- **ADAPTOR SLEEVES**
- **WITHDRAWAL SLEEVES**
- **STEEL BALLS**
- **NEEDLE ROLLERS**
- **AUTOMOTIVE BEARINGS**



SEALS

OIL SEALS & BEARINGS CENTRE LTD. is proud to hold the widest range of seals and seal related products. The entire components of sealing technology is available from stock or made to order. OIL SEALS & BEARINGS CENTRE LTD. has extensive expertise in hydraulic cylinder sealing and cater to the niche needs of earth moving, mining, agricultural and manufacturing industries.

- OIL SEALS
- HYDRAULIC SEALS
- MECHANICAL SEALS
- O-RINGS
- BACK-UP RINGS
- ROTARY SHAFT SEALS
- V SEALS
- PNEUMATIC SEALS



CUSTOM MADE SEALS

In addition to an extensive stock holding of seal products, customized seals can be manufactured using our own SEAL MAKING machine, allowing OIL SEALS & BEARINGS CENTRE LTD. to meet customer requirements with precision and accuracy.

Customized seals can be manufactured using our own seal making made-to-order facility while the client waits.

- TORRIC SEALS
- HYDRAULIC CYLINDER SEALS
- BACK UP RINGS
- DOUBLE ACTING SEAL
- PTFE GUIDES
- ROD WIPER SEALS
- V SEALS
- PNEUMATIC SEALS



MAINTENANCE

PRODUCTS

OIL SEALS & BEARINGS CENTRE LTD. enables customers to enjoy easy access to a vast and well stocked range of maintenance products that are insight driven and reliable.

- ALLUMINIUM HEATING RINGS
- BACK PULLERS
- BALL BEARING PULLERS
- BEARING FITTING KITS
- BELT ALIGNMENT TOOLS
- COMBINATION KITS
- FEELER GUAGES
- HOOK SPANNERS
- HYDRAULIC PULLERS
- HYDRAULIC SPINDLES
- IMPACT SPANNERS
- INDUCTION HEATERS
- INTERNAL PULLERS
- JAW PULLERS
- LOCKING NUT KITS
- TRI-SECTION PULLING PLATES

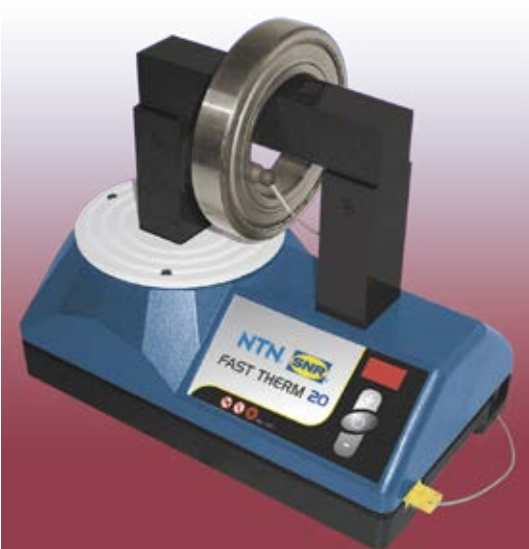
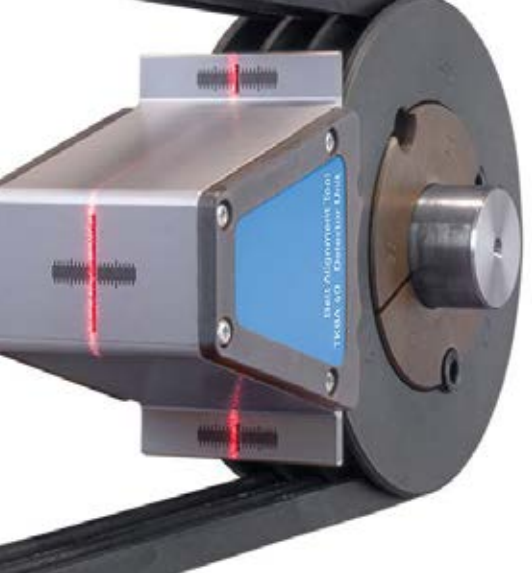

LUBRICATION

OIL SEALS & BEARINGS CENTRE LTD. provide a turnkey solution to ensure production equipment is effectively lubricated and performance is enhanced.

The components which make up the lubrication systems and devices are all available.

- **AUTOMATIC LUBRICATORS**
- **BEARING LUBRICATORS**
- **CENTRALISED LUBRICATORS**
- **DRIP LUBRICATORS**
- **GAS LUBRICATORS**
- **MIST LUBRICATORS**
- **BEARING GREASES**
- **HIGH TEMPRATURE GREASES**
- **HIGH SPEED GREASES**
- **FOOD GRADE GREASES**



HYDRAULICS

OIL SEALS & BEARINGS CENTRE LTD. stocks the widest range of hydraulic kits and seals. Supporting this product offering are value added services that include repairs and services .

The extensive knowledge in hydraulics, and continual training is the foundation on which OIL SEALS & BEARINGS CENTRE LTD. success in this field is built.

- **REPAIRS AND SERVICING OF HYDRAULIC CYLINDERS**
- **REPAIR AND SERVICING OF HYDRAULIC PISTONS**
- **REPAIR AND SERVICING OF HYDRAULIC RAMS**

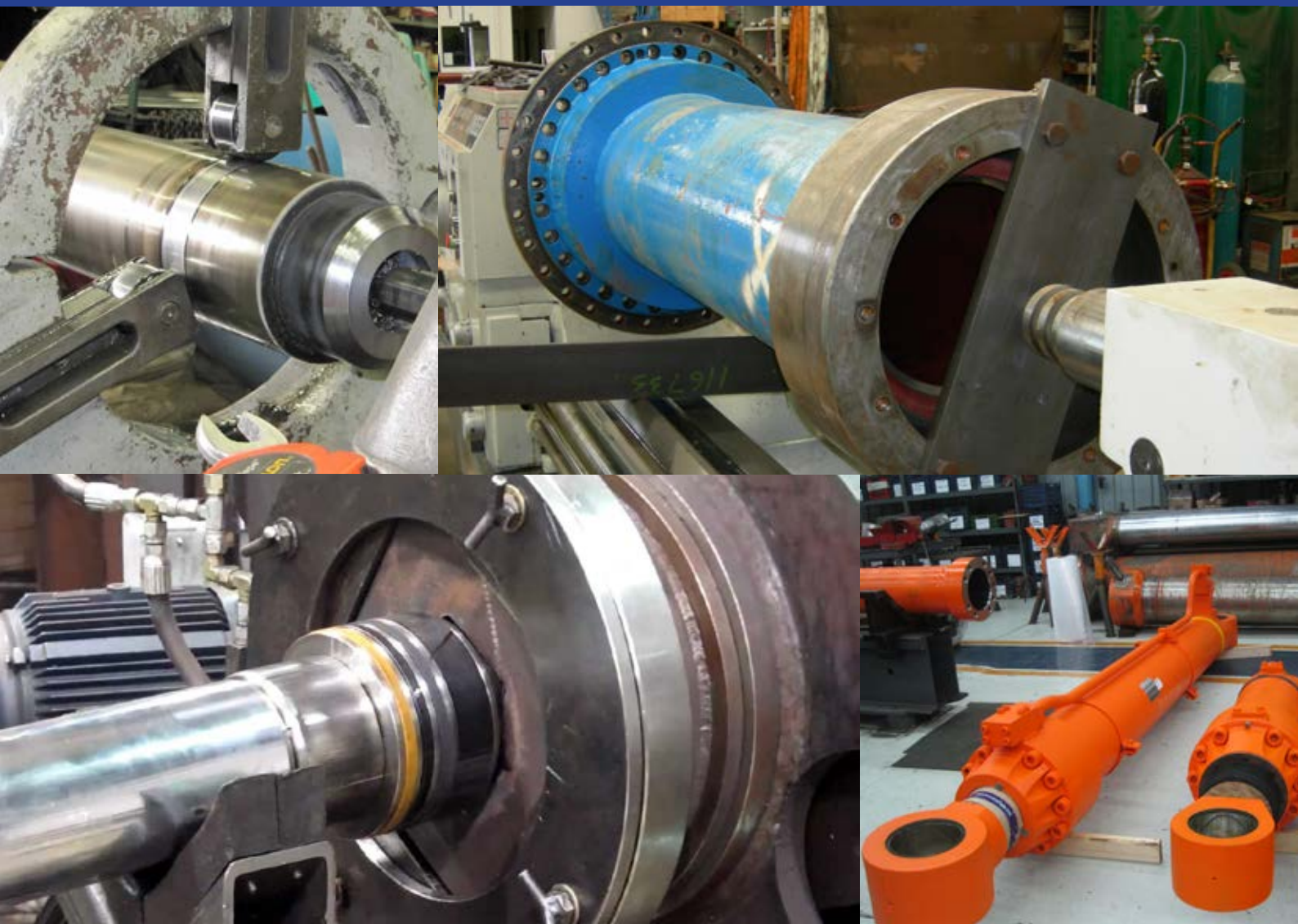

SPROCKETS & WHEELS

The sprockets and wheels are imported from well known manufacturers of chains. This makes OIL SEALS & BEARINGS CENTRE LTD. range of sprockets extensive and ideal for users. The quality inspection procedures are quite thorough and the range also includes both taper bore and pilot bore sprockets in simplex, duplex and triplex. Conveyor chain wheels and special manufactured sprockets are available on request and supplied as per customer specifications.

- PILOT BORE SPROCKETS
- TAPER LOCK TYPE SPROCKETS
- CONVEYOR CHAIN WHEELS
- SLAT BAND WHEELS

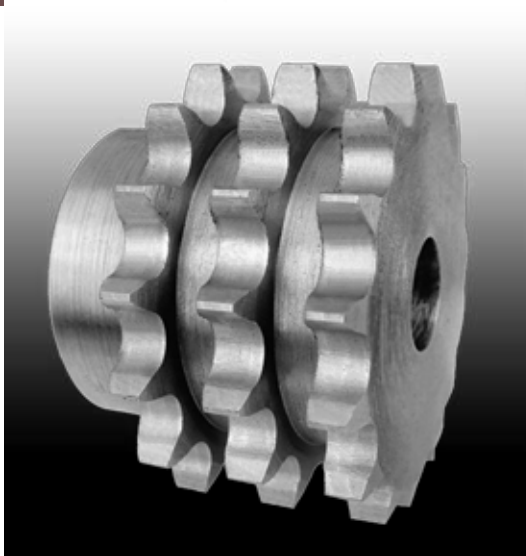
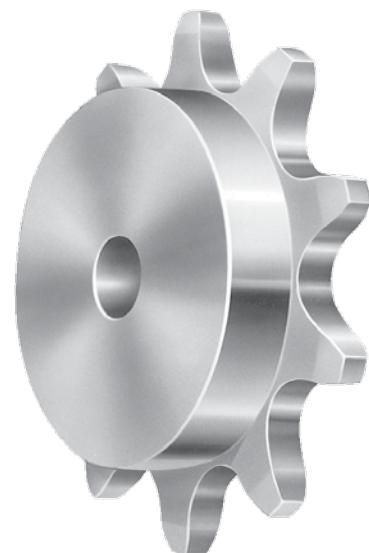
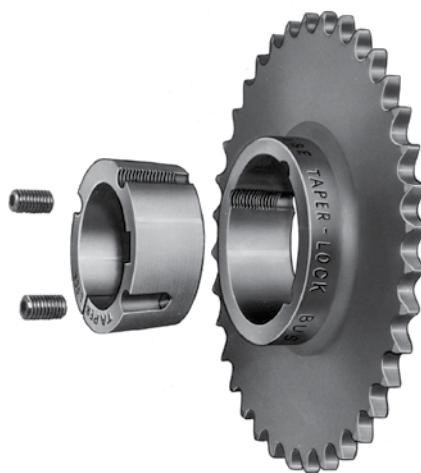

CHAINS

OIL SEALS & BEARINGS CENTRE LTD. supplies an extensive range of roller, leaf, timber, agricultural, bottling and conveyor chains for all manufacturing industries in

Kenya. The chains are imported from well known chain manufacturers who follow strict quality controls.

A full range of attachments are also available and are of various types and designs of chain to suit customer specific requirements.

OIL SEALS & BEARINGS CENTRE LTD. supply chains manufactured to suit customer specifications and this makes an ideal choice for any new build or replacement.

- **ROLLER CHAINS**
- **CONVEYOR CHAINS**
- **BAGGASE CHAINS**
- **CANE CARRIER CHAINS**
- **COMBINE HARVESTER CHAINS**
- **DROP FORGED CHAINS**
- **ELEVATOR CHAINS**
- **OVERHEAD CHAINS**
- **PINTLE CHAINS**
- **PLASTIC SLAT BAND CHAINS**
- **STEEL SLAT BAND CHAINS**
- **SCRAPPER CHAINS**

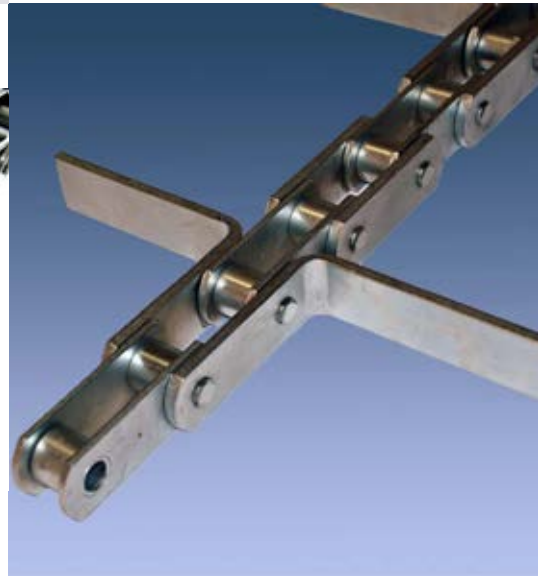
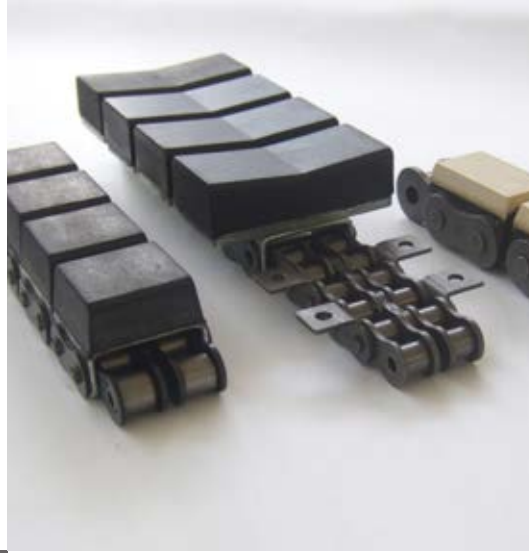

SHAFT COUPLINGS

OIL SEALS & BEARINGS CENTRE LTD. range of couplings covers most of the industry requirements. The range encompasses from large couplings for power generation turbines to small couplings for mini water pumps.

The entire compliment of coupling products is available from stock and special types ordered from manufactures to meet customer requirements.

- **CHAIN COUPLINGS**
- **DISC COUPLINGS**
- **EUPEX COUPLINGS**
- **TYRE COUPLINGS**
- **STAR COUPLINGS**
- **JAW COUPLINGS**
- **PIN COUPLING**
- **RIGID COUPLING**
- **ROTEX COUPLINGS**

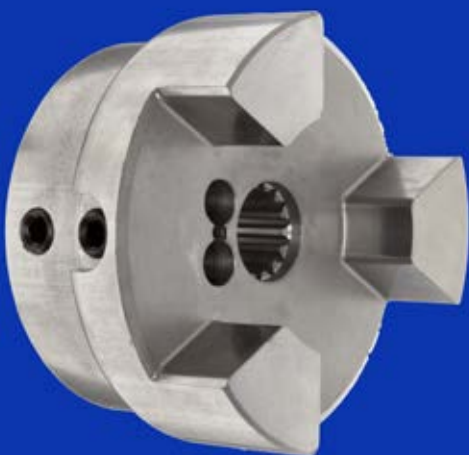
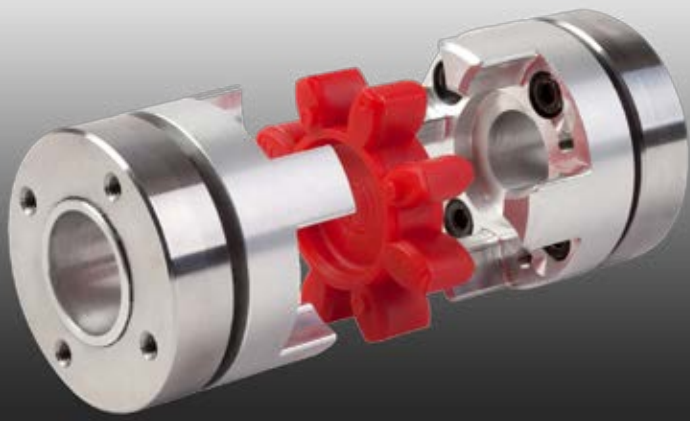

TAPER BUSHES & HUBS

With over 500 metric and imperial bore sizes of taper bushes being available and manufactured from close grade cast iron, OIL SEALS & BEARINGS CENTRE LTD. ensures to have the quality taper bush. The taper bush and hubs are of high machining tolerances. OIL SEALS & BEARINGS CENTRE LTD. has an extended range of components of precision machined steel weld on hubs as well as extended range of keyed and keyless adaptors.

- TAPER LOCK BUSHES
- WELD ON HUBS
- ADAPTORS



PULLEYS

OIL SEALS & BEARINGS CENTRE LTD. proudly supplies the range of Vee Pulleys to industries helping to maximize operational up-time at manufacturing plants, The extensive, unbeaten OIL SEALS & BEARINGS CENTRE LTD. product range includes Vee pulleys in all sizes from giant mining crushers to small chaff cutters.

- VEE PULLEYS PILOT BORED
- VEE PULLEYS TAPER LOCK TYPE
- STEP PULLEYS
- SPRING LOADED VARIABLE SPEED PULLEYS

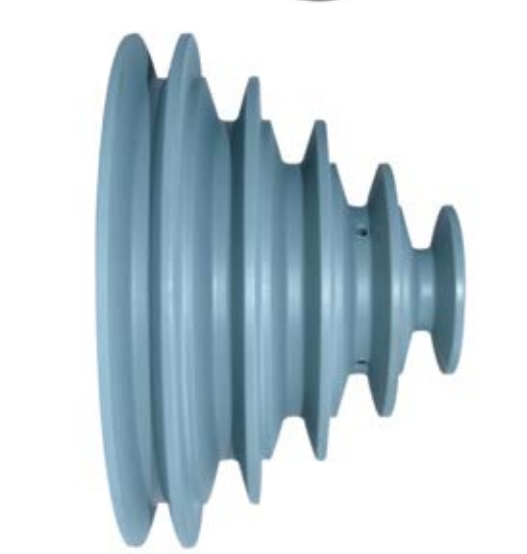

VEE BELTS **& TIMING BELTS**

OIL SEALS & BEARINGS CENTRE LTD. provide the best belts that have a long service life. With a wide range available in stock and at affordable price, customer satisfaction is priority. The speciality range caters for both light and heavy industry applications.

- **IMPERIAL VEE BELTS**
- **METRIC VEE BELTS**
- **TIMING BELTS**
- **RIBBED BELTS**
- **BANDED BELTS**
- **VARIABLE SPEED BELTS**
- **COGGED BELTS**
- **DOUBLE SIDED BELTS**
- **HEXAGON BELTS**
- **SYNCRONISED BELTS**

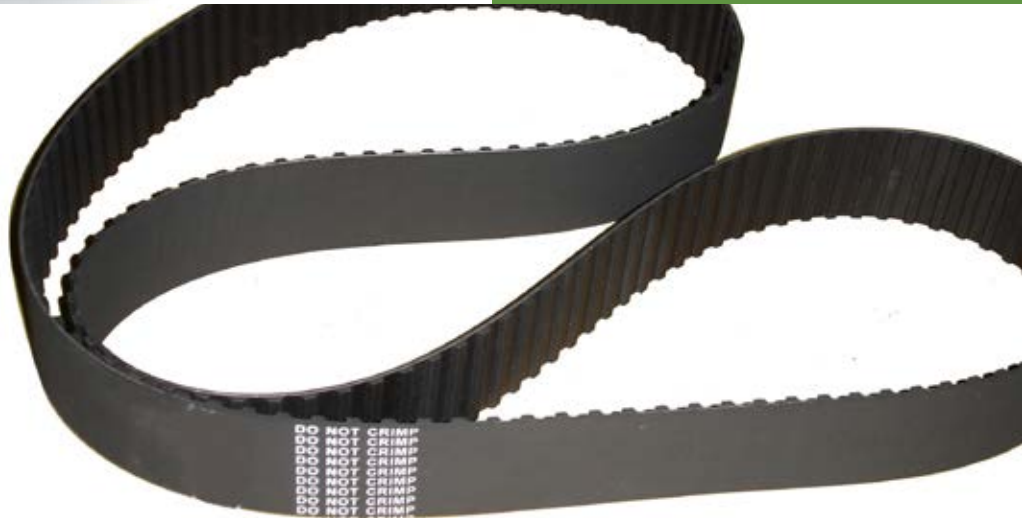
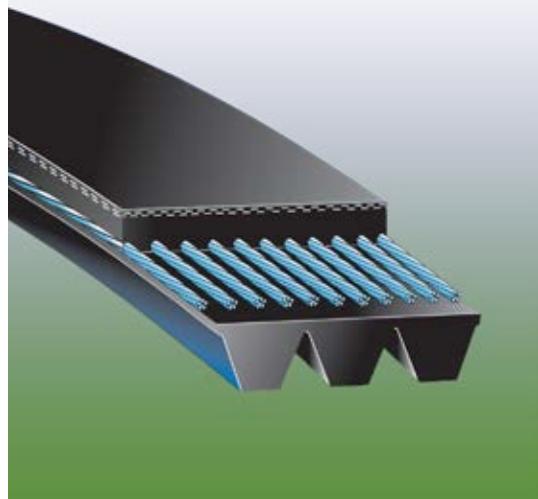
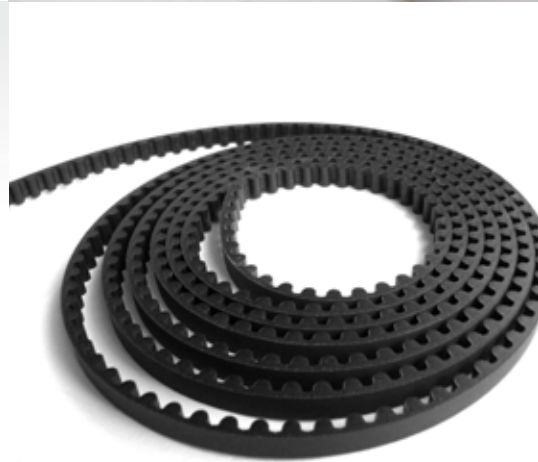



OIL SEALS & BEARINGS CENTRE LTD.

20 - Dar-es-Salaam Road, Industrial Area

P. O. Box 59000 - 00200 City Square, Nairobi, Kenya.

Tel: +254 020 6536655/6/7, 6651622/3/4/5

Wireless: 020 2613193 | Cell: 0770 575 692/3, 0735 755 353

Fax: +254 20 6535330

Email: info@osbcl.com / sales@osbcl.com / osbcl12@gmail.com

Website: www.osbcl.com

**BEARINGS | SEALS | MAINTENANCE PRODUCTS | LUBRICANTS
HYDRAULICS | CHAINS | SPROCKETS | COUPLINGS
TAPER BUSHES | VEE BELTS | VEE PULLEYS**